

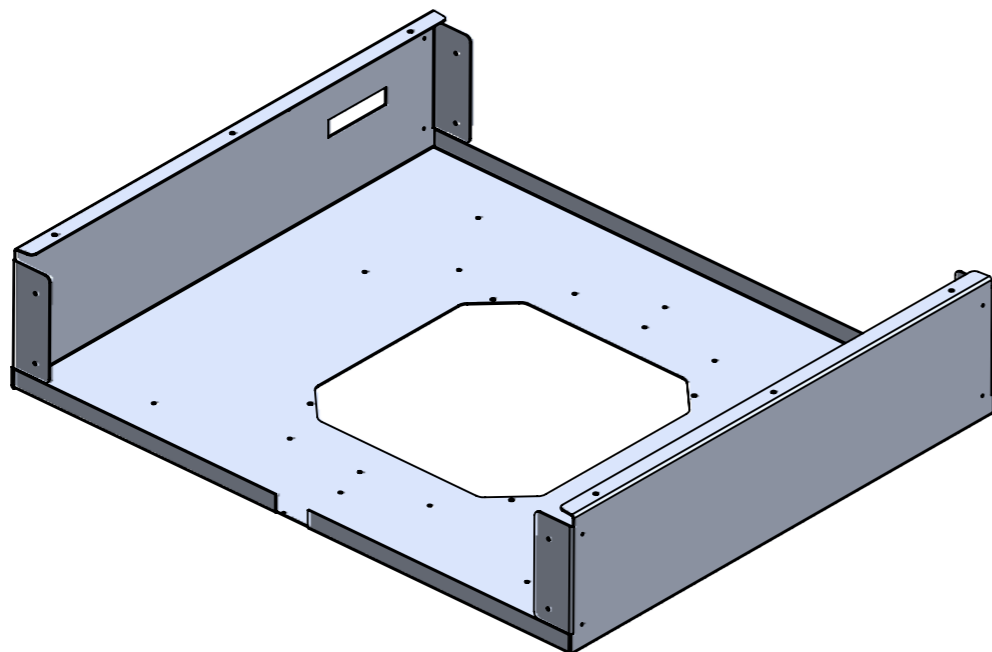

| POS-NR. | BENENNUNG | BESCHREIBUNG | MENGE |
|---------|-----------|---------------------|-------|
| 1 | CAS-01-01 | Gehäuseteil 1 | 1 |
| 2 | CAS-01-02 | Gehäuseteil 2 | 1 |
| 3 | CAS-01-03 | Luftleitblech 1 | 1 |
| 4 | CAS-01-04 | Luftleitblech 2 | 1 |
| 5 | CAS-01-05 | Deckel Ausblasseite | 2 |
| 6 | CAS-01-06 | Gitter Ansaugseite | 1 |
| 7 | CAS-01-07 | Schiene Filter | 2 |
| 8 | CAS-01-08 | Anschlag Filter | 1 |
| 9 | CAS-01-09 | Deckenmontageblech | 1 |
| 11 | CAS-01-10 | Schutzgitter | 2 |

| | | | | | | | | |
|--|--|--|--|--|------------------------------------|--|----------------|--|
| | | | ENTGRATEN UND SCHARFE KANTEN BRECHEN | | ZEICHNUNG NICHT SKALIEREN | | Massstab: | |
| | | | WERKSTOFF: Aluminium | | GEWICHT: 6.81 | | | |
| GEZEICHNET: West GEPRÜFT: GENEHMIGT: PRODUKTION: QUALITÄT: | | | NAME: West SIGNATUR: DATUM: 28.01.2021 | | BENENNUNG: Clean Air Sky | | | |
| | | | | | ZEICHNUNGSNR. CAS-01-000 | | A3 | |
| | | | | | ÄNDERUNG: | | BLATT 1 VON 11 | |

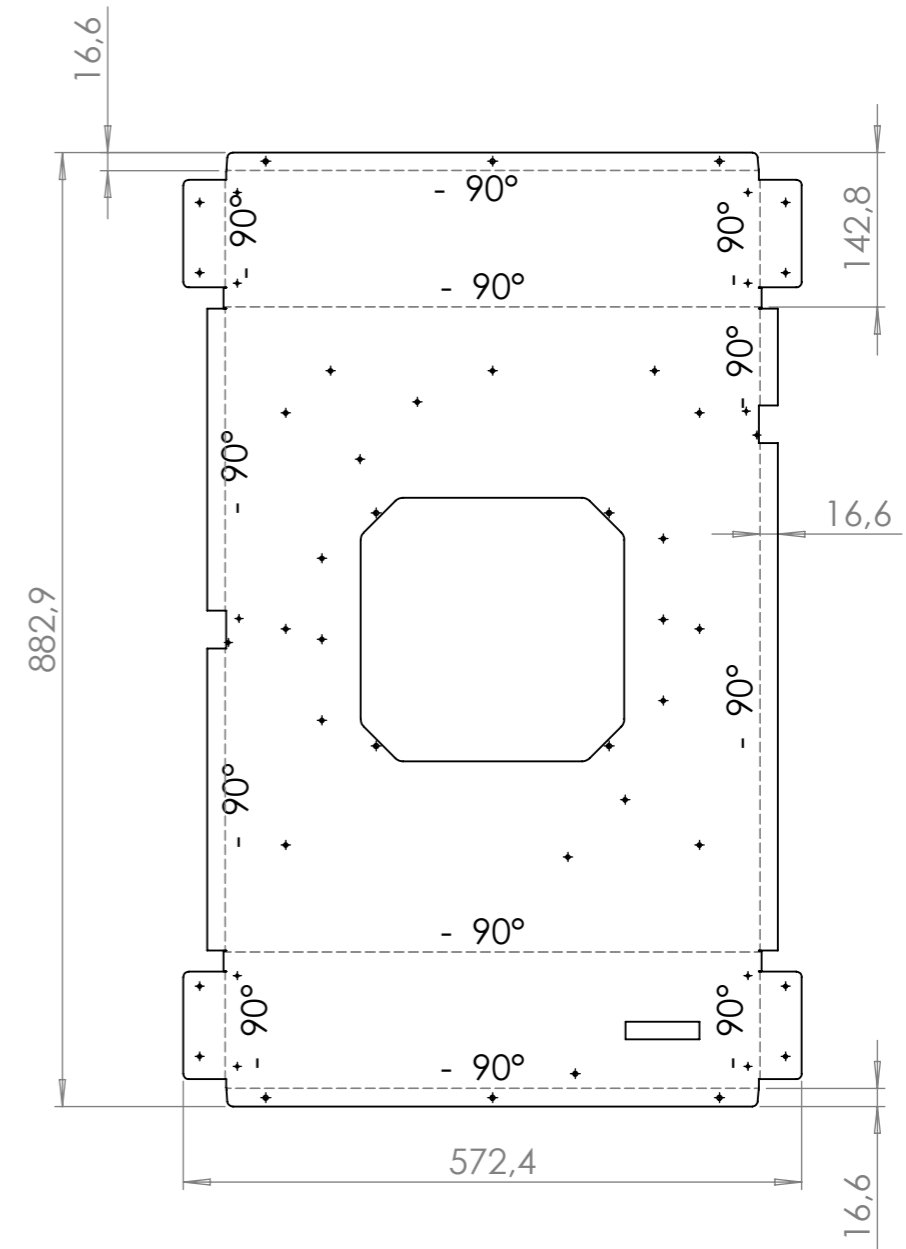
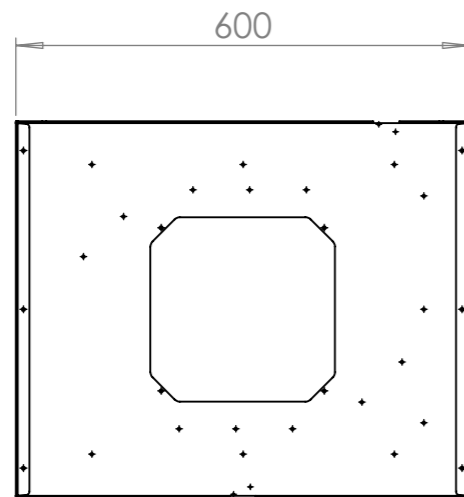
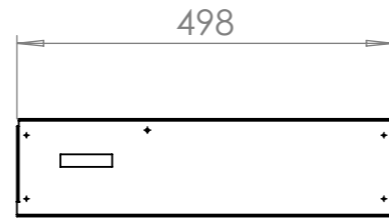
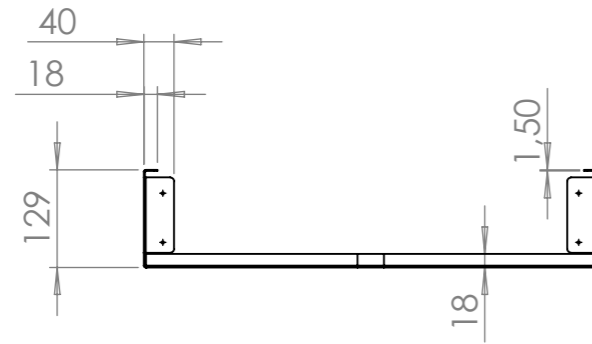

t=1,5mm Aluminium

| | | | | | | | | |
|---|------|----------|-------|--------------------------------------|--|------------------------------------|--|------------------|
|  | | | | ENTGRATEN UND SCHARFE KANTEN BRECHEN | | ZEICHNUNG NICHT SKALIEREN | | Massstab: |
| | | | | WERKSTOFF: 3.3535 (EN-AW 5754) | | BENENNUNG: Gehäuseteil 1 | | GEWICHT: 1.65 |
| GEZEICHNET | NAME | SIGNATUR | DATUM | ZEICHNUNGSNR. CAS-01-01 | | | | A3 |
| GEPRÜFT | | | | ÄNDERUNG | | | | |
| GENEHMIGT | | | | BLATT 2 VON 11 | | | | |
| PRODUKTION | | | | | | | | |
| QUALITÄT | | | | | | | | |

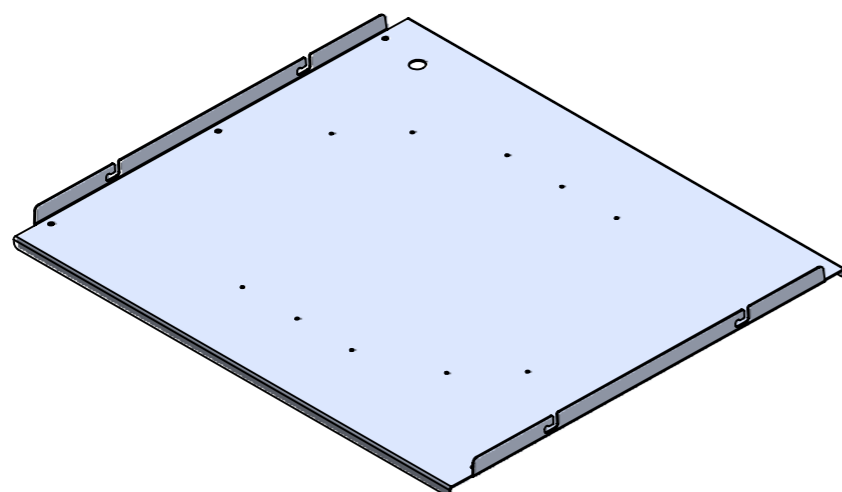
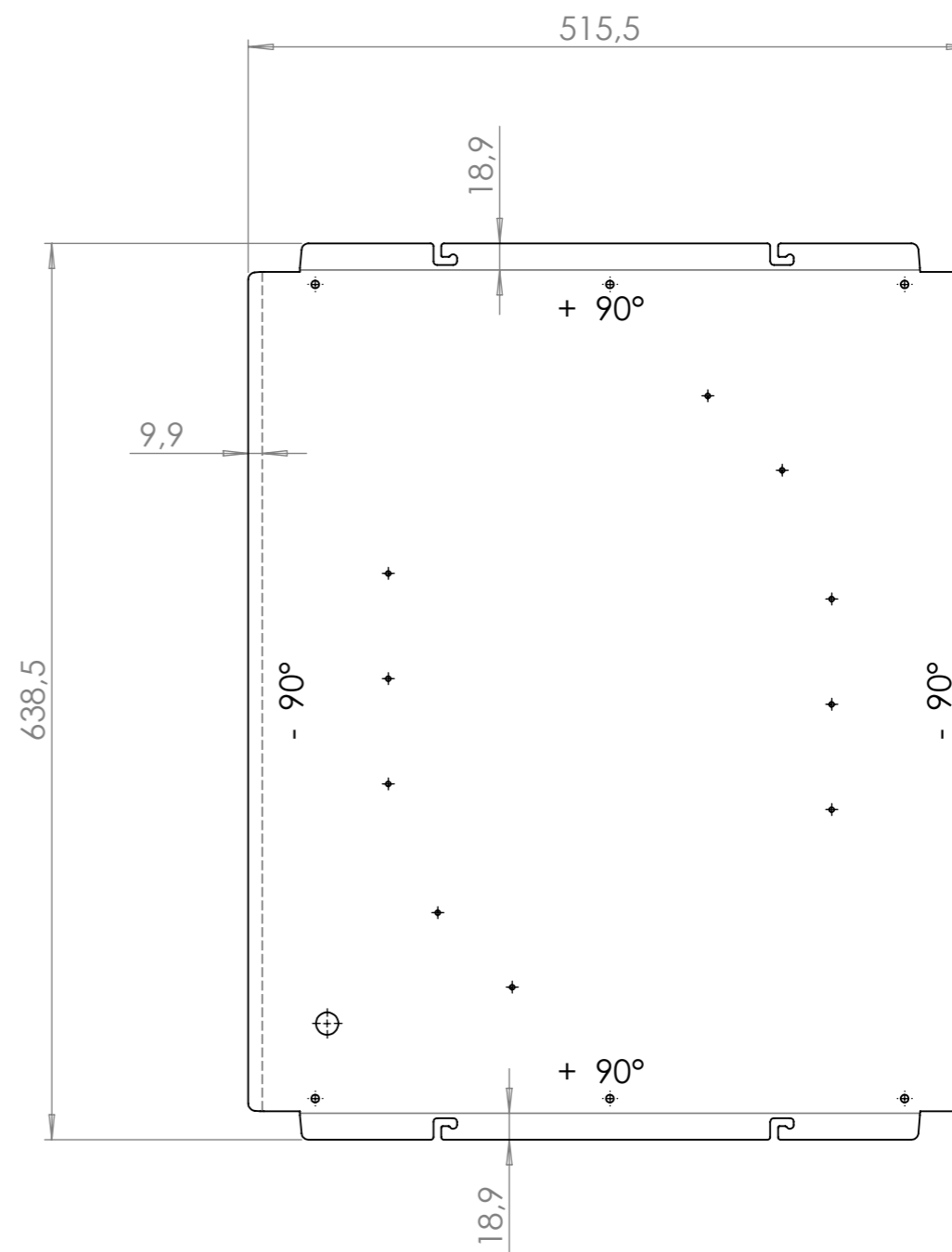
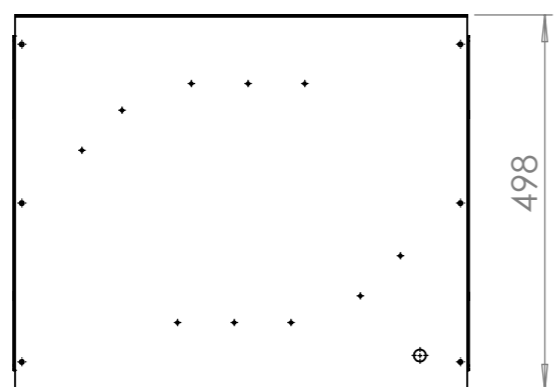
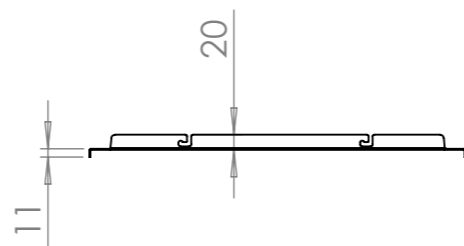
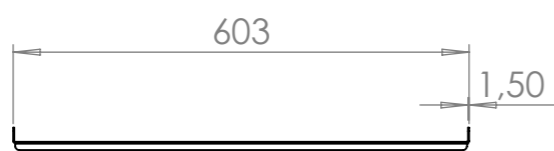

t=1,5mm Aluminium

|  | | | | ENTGRATEN UND SCHARFE KANTEN BRECHEN | | ZEICHNUNG NICHT SKALIEREN | | Massstab: | | | | | | | | | | | | | | | | | | | | | | | | | | | |
|--|------|----------|------------|--------------------------------------|------|---------------------------|-------|------------|------|--|------------|---------|--|--|--|-----------|--|--|--|------------|--|--|--|----------|--|--|--|------------------------------------|--|--|--|----------------------------|--|----|--|
| | | | | WERKSTOFF: 3.3535 (EN-AW 5754) | | GEWICHT: 1.30 | | | | | | | | | | | | | | | | | | | | | | | | | | | | | |
| <table border="1"> <thead> <tr> <th></th> <th>NAME</th> <th>SIGNATUR</th> <th>DATUM</th> </tr> </thead> <tbody> <tr> <td>GEZEICHNET</td> <td>West</td> <td></td> <td>28.01.2021</td> </tr> <tr> <td>GEPRÜFT</td> <td></td> <td></td> <td></td> </tr> <tr> <td>GENEHMIGT</td> <td></td> <td></td> <td></td> </tr> <tr> <td>PRODUKTION</td> <td></td> <td></td> <td></td> </tr> <tr> <td>QUALITÄT</td> <td></td> <td></td> <td></td> </tr> </tbody> </table> | | | | | NAME | SIGNATUR | DATUM | GEZEICHNET | West | | 28.01.2021 | GEPRÜFT | | | | GENEHMIGT | | | | PRODUKTION | | | | QUALITÄT | | | | BENENNUNG: Gehäuseteil 2 | | | | ZEICHNUNGSNR. CAS-01-02 | | A3 | |
| | NAME | SIGNATUR | DATUM | | | | | | | | | | | | | | | | | | | | | | | | | | | | | | | | |
| GEZEICHNET | West | | 28.01.2021 | | | | | | | | | | | | | | | | | | | | | | | | | | | | | | | | |
| GEPRÜFT | | | | | | | | | | | | | | | | | | | | | | | | | | | | | | | | | | | |
| GENEHMIGT | | | | | | | | | | | | | | | | | | | | | | | | | | | | | | | | | | | |
| PRODUKTION | | | | | | | | | | | | | | | | | | | | | | | | | | | | | | | | | | | |
| QUALITÄT | | | | | | | | | | | | | | | | | | | | | | | | | | | | | | | | | | | |
| | | | | ÄNDERUNG | | BLATT 3 VON 11 | | | | | | | | | | | | | | | | | | | | | | | | | | | | | |

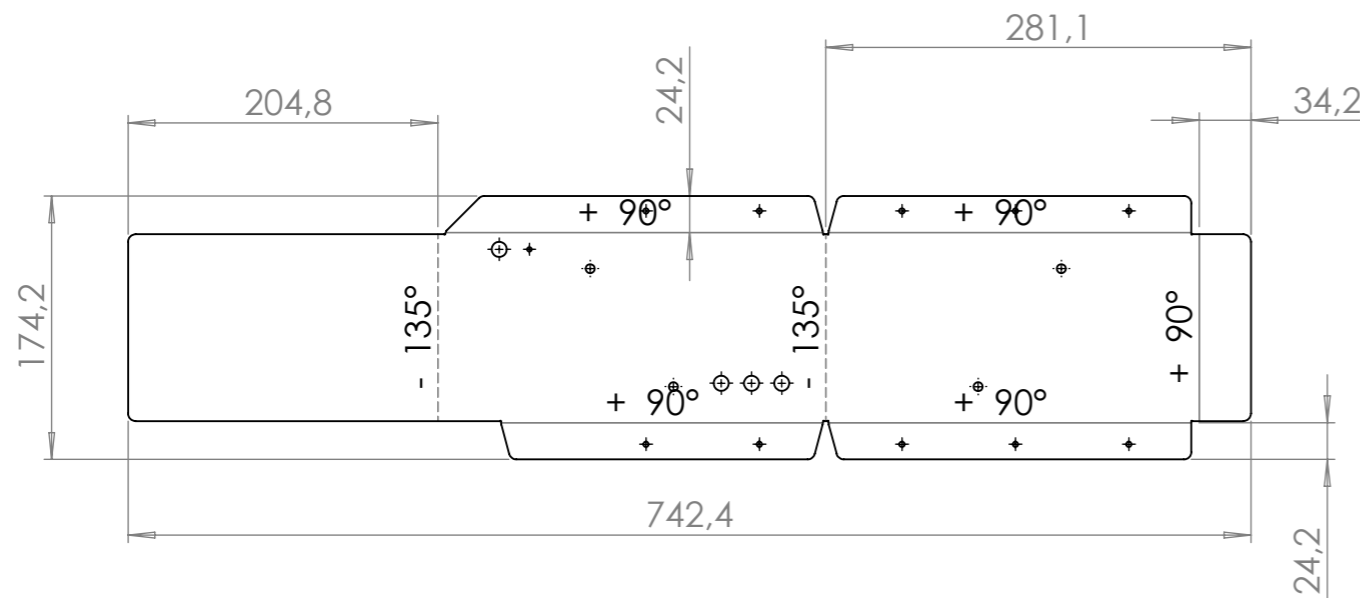
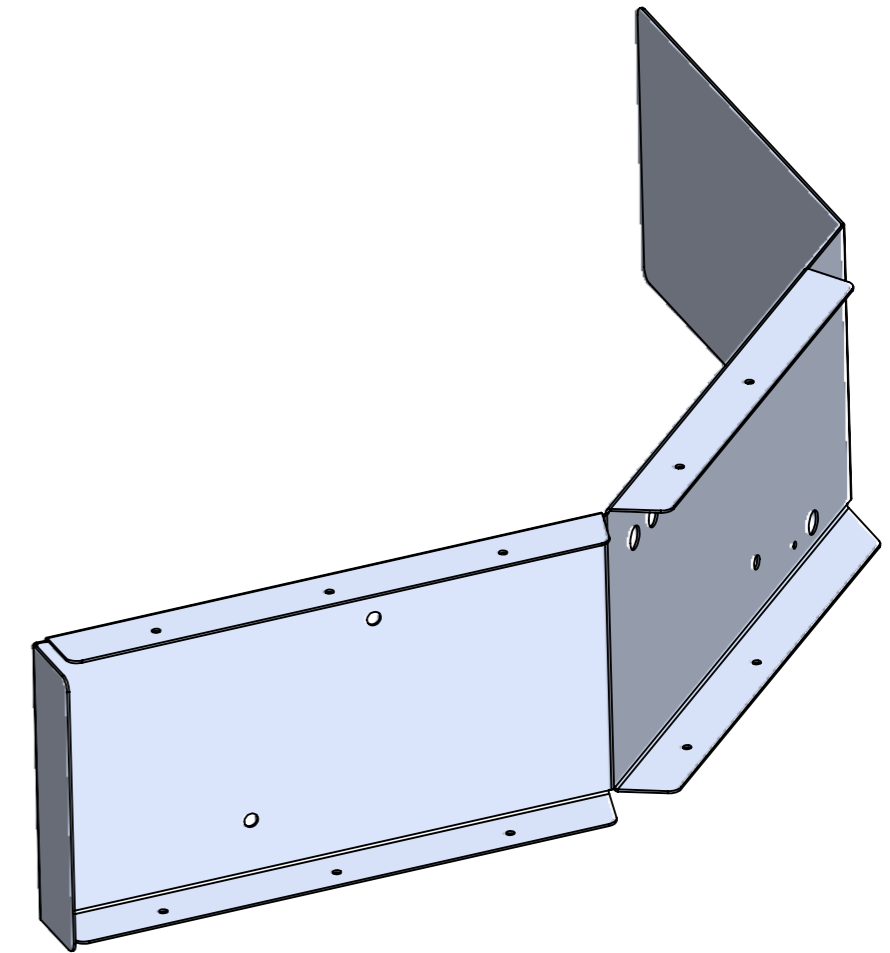
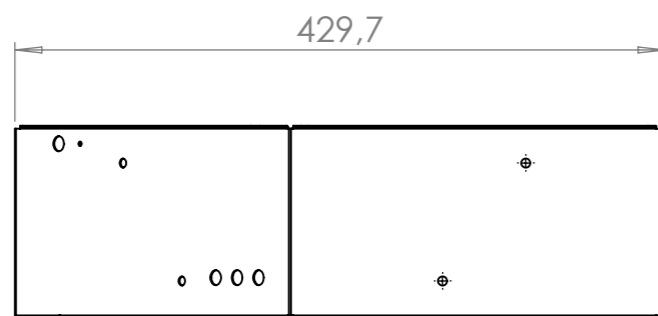
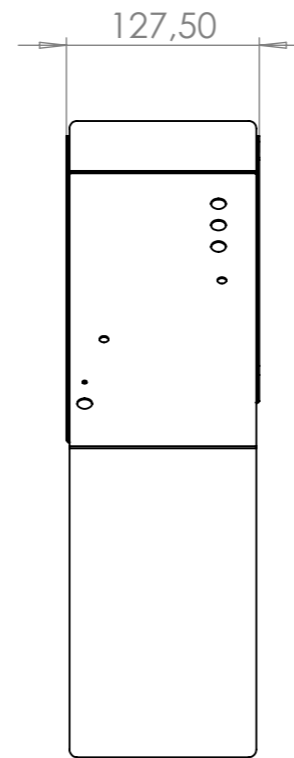
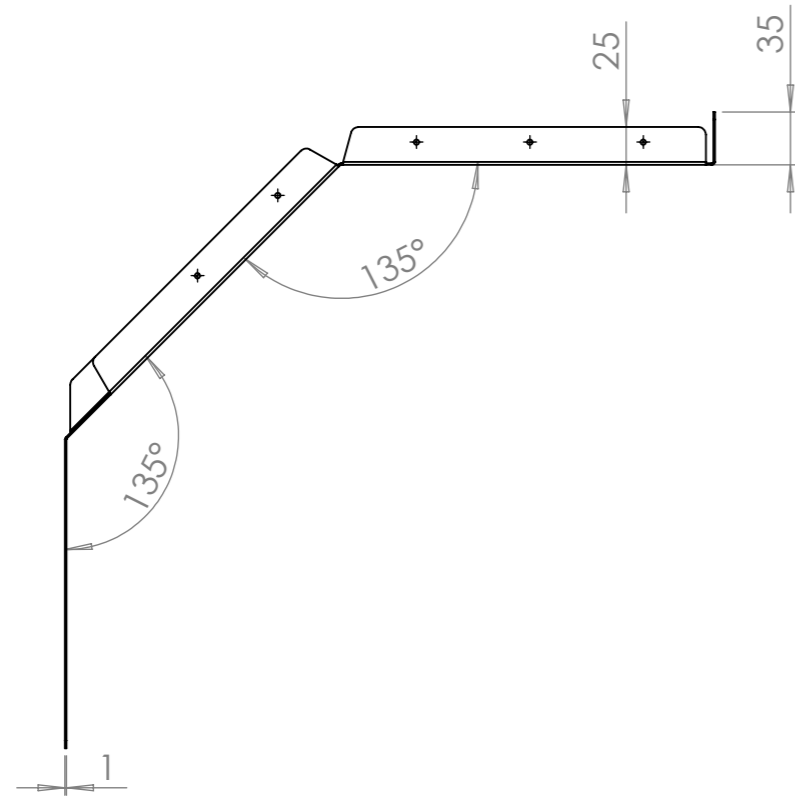

t=1mm Aluminium

| | | | | | | | | | |
|---|--|--|--|--------------------------------------|--|---------------------------|--|-----------|--|
|  | | | | ENTGRATEN UND SCHARFE KANTEN BRECHEN | | ZEICHNUNG NICHT SKALIEREN | | Massstab: | |
| | | | | WERKSTOFF: 3.3535 (EN-AW 5754) | | GEWICHT: 0.30 | | | |
| BENENNUNG: Luffleitblech 1 | | | | ZEICHNUNGSNR. CAS-01-03 | | ÄNDERUNG | | A3 | |
| GEZEICHNET West GEPRÜFT GENEHMIGT PRODUKTION QUALITÄT | | | | NAME SIGNATUR DATUM 28.01.2021 | | BLATT 4 VON 11 | | | |

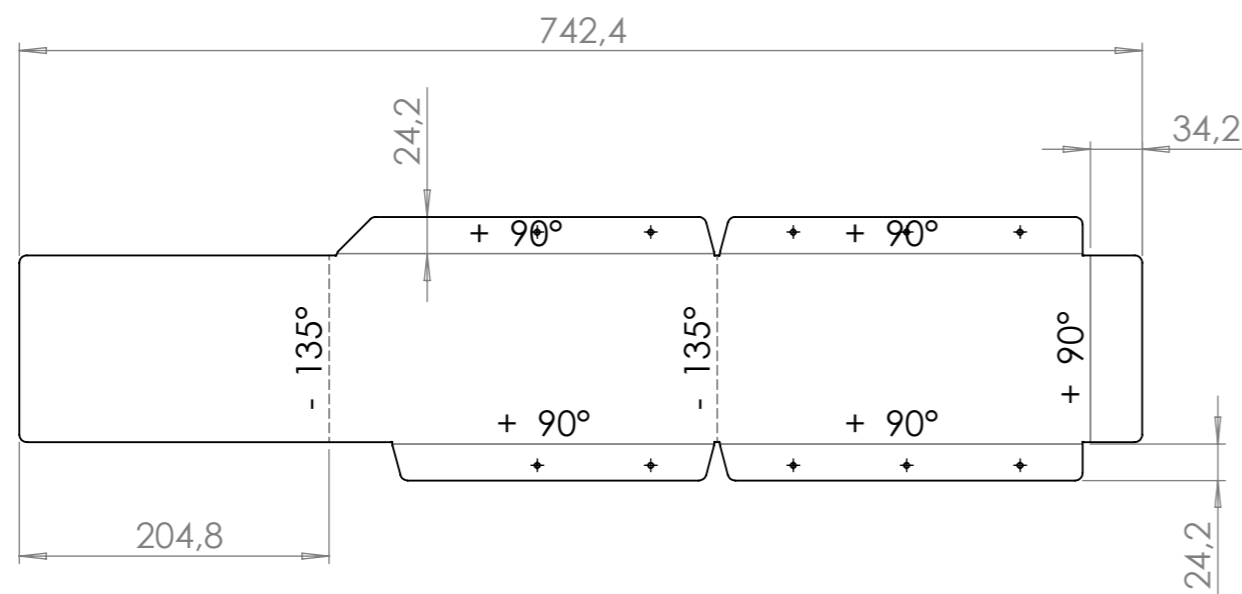
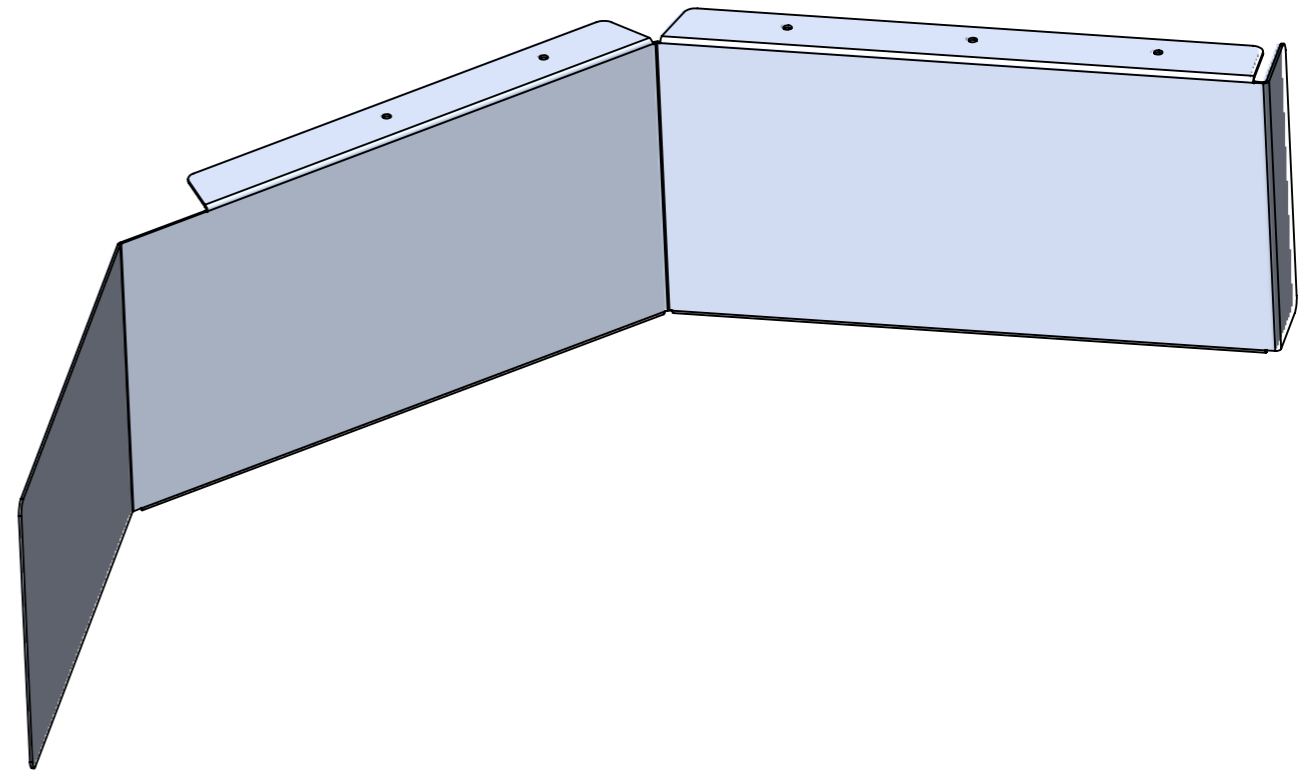
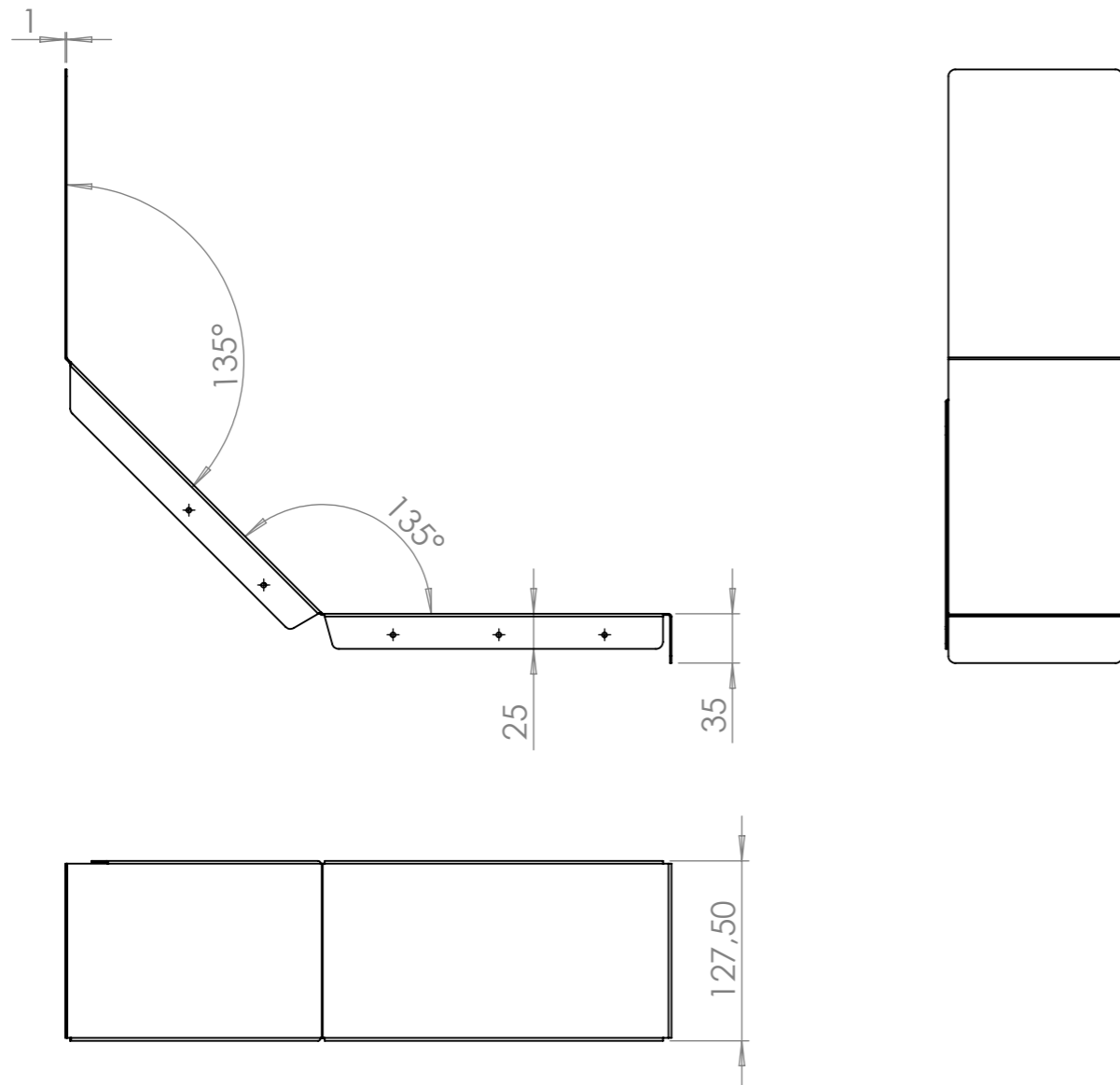

t=1mm Aluminium

| | | | | | | | | | |
|---|------|----------|------------|--------------------------------------|--|---------------------------|--|-----------|--|
|  | | | | ENTGRATEN UND SCHARFE KANTEN BRECHEN | | ZEICHNUNG NICHT SKALIEREN | | Massstab: | |
| | | | | WERKSTOFF: 3.3535 (EN-AW 5754) | | GEWICHT: 0.31 | | | |
| | | | | BENENNUNG: Luffleitblech 2 | | | | | |
| | | | | ZEICHNUNGSNR. CAS-01-04 | | | | A3 | |
| | | | | ÄNDERUNG | | BLATT 5 VON 11 | | | |
| GEZEICHNET | NAME | SIGNATUR | DATUM | | | | | | |
| GEPRÜFT | West | | 28.01.2021 | | | | | | |
| GENEHMIGT | | | | | | | | | |
| PRODUKTION | | | | | | | | | |
| QUALITÄT | | | | | | | | | |

2 STK

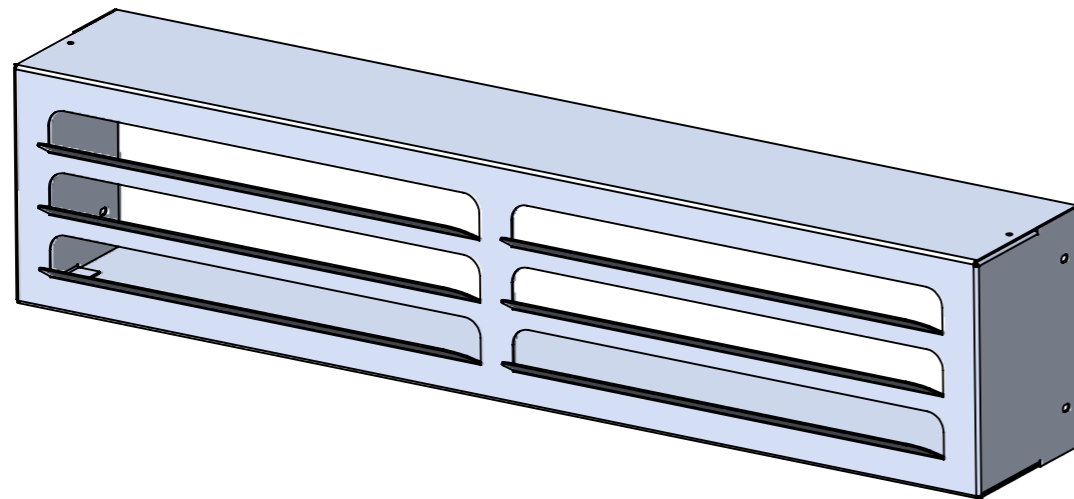
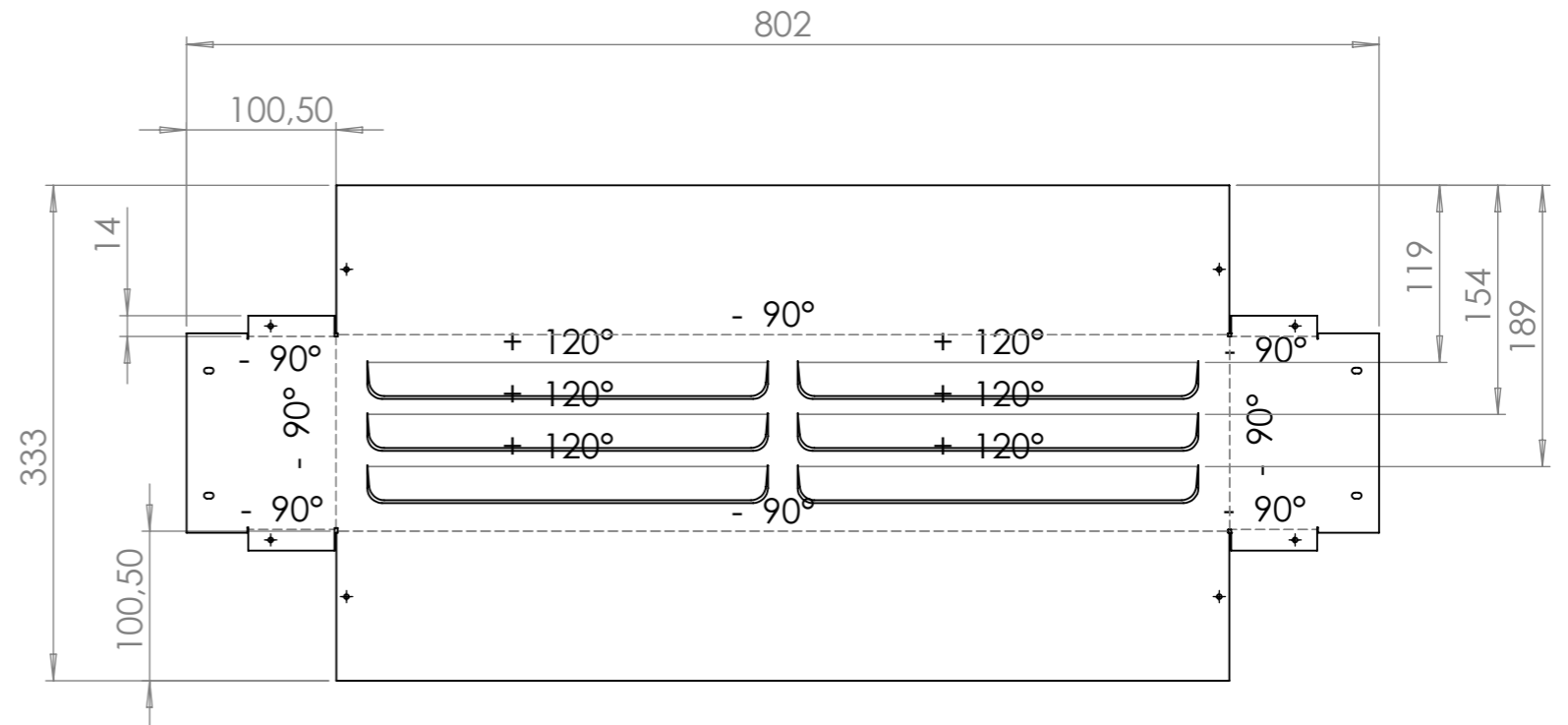
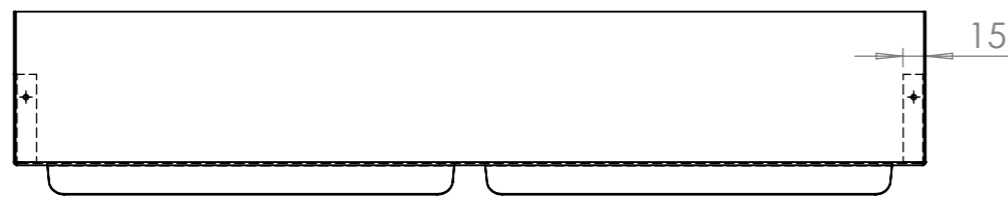
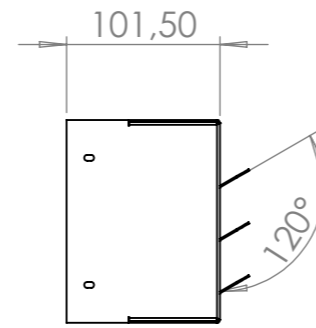
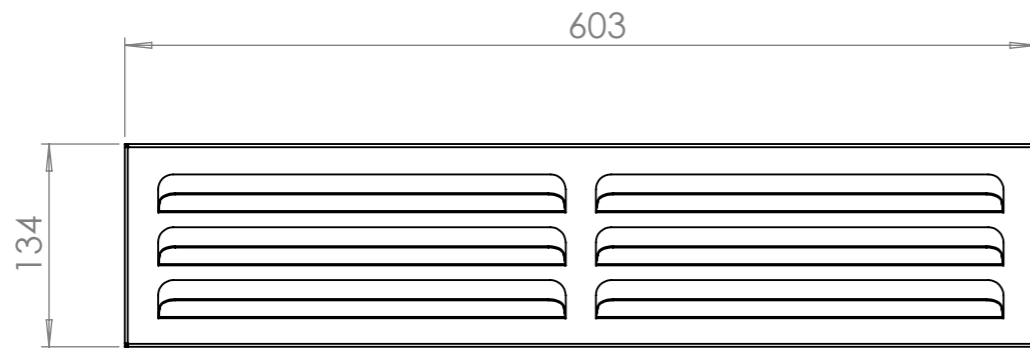

t=1mm Aluminium

| | | | | | | | | |
|---|--|--|--|--------------------------------------|--|---------------------------|--|-----------|
|  | | | | ENTGRATEN UND SCHARFE KANTEN BRECHEN | | ZEICHNUNG NICHT SKALIEREN | | Massstab: |
| | | | | WERKSTOFF: 3.3535 (EN-AW 5754) | | GEWICHT: 0.60 | | |
| BENENNUNG: Deckel Ausblasseite | | | | ZEICHNUNGSNR. CAS-01-05 | | A3 | | |
| ÄNDERUNG | | | | BLATT 6 VON 11 | | | | |

| | NAME | SIGNATUR | DATUM |
|------------|------|----------|------------|
| GEZEICHNET | West | | 28.01.2021 |
| GEPRÜFT | | | |
| GENEHMIGT | | | |
| PRODUKTION | | | |
| QUALITÄT | | | |

2 STK

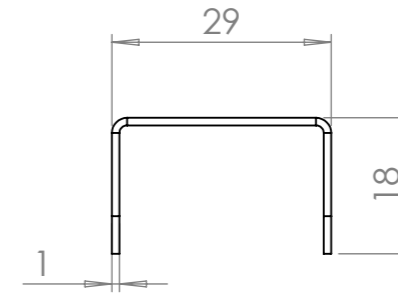
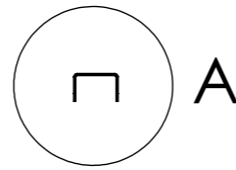
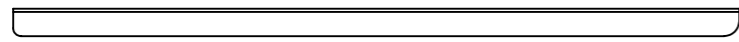

DETAIL A
MAßSTAB 1 : 1

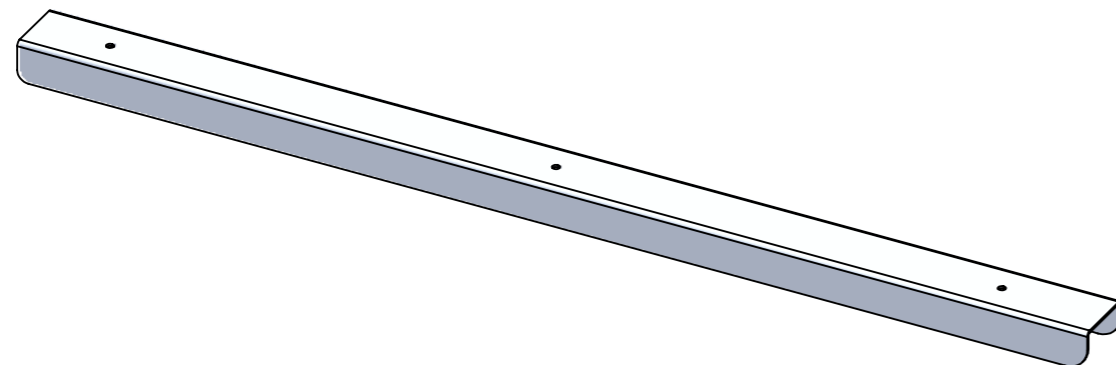
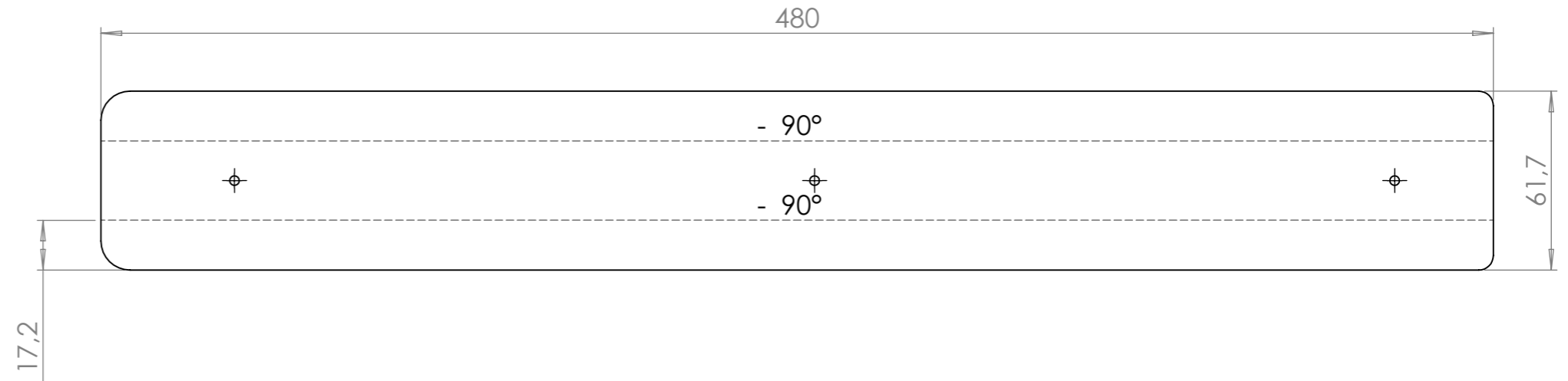
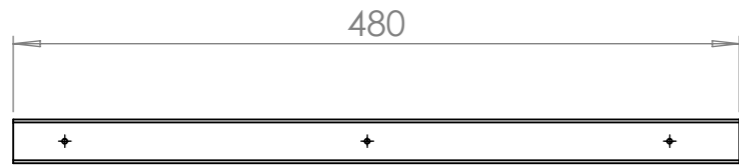

t=1mm Aluminium

| | | | | | | | | | |
|---|------|----------|------------|--------------------------------------|--|---------------------------|--|-----------|--|
|  | | | | ENTGRATEN UND SCHARFE KANTEN BRECHEN | | ZEICHNUNG NICHT SKALIEREN | | Massstab: | |
| | | | | WERKSTOFF: 3.3535 (EN-AW 5754) | | GEWICHT: 0.08 | | | |
| | | | | BENENNUNG: Schiene Filter | | | | | |
| | | | | ZEICHNUNGSNR. CAS-01-07 | | | | A3 | |
| | | | | ÄNDERUNG | | BLATT 7 VON 11 | | | |
| GEZEICHNET | NAME | SIGNATUR | DATUM | | | | | | |
| GEPRÜFT | West | | 28.01.2021 | | | | | | |
| GENEHMIGT | | | | | | | | | |
| PRODUKTION | | | | | | | | | |
| QUALITÄT | | | | | | | | | |

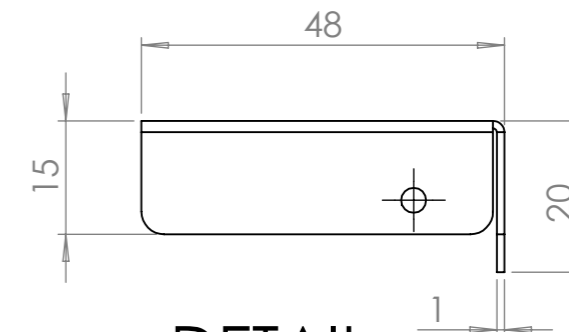
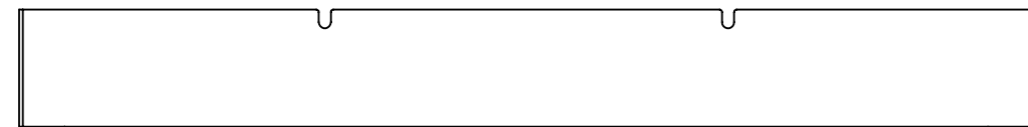
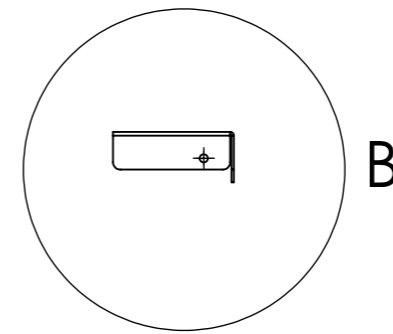
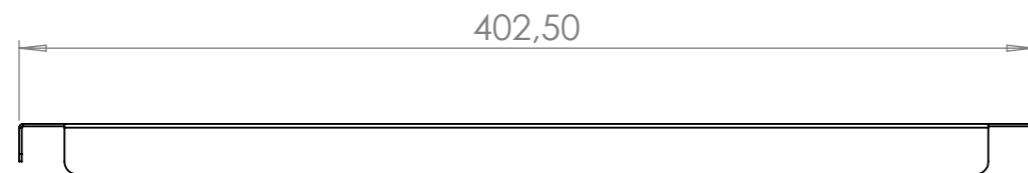

DETAIL B
MAßSTAB 1 : 1

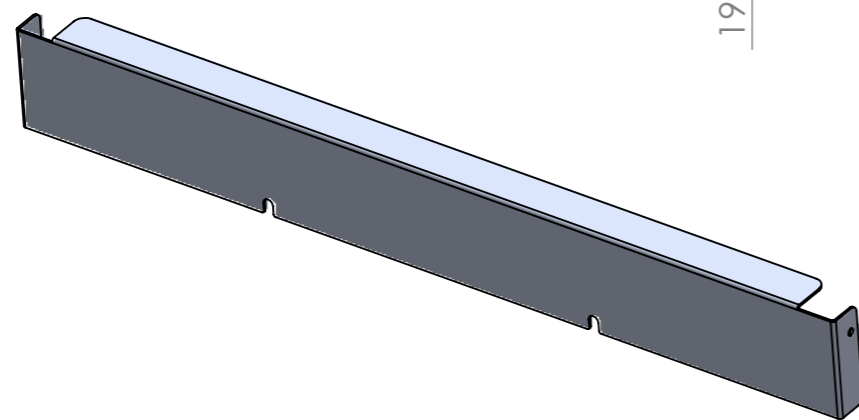
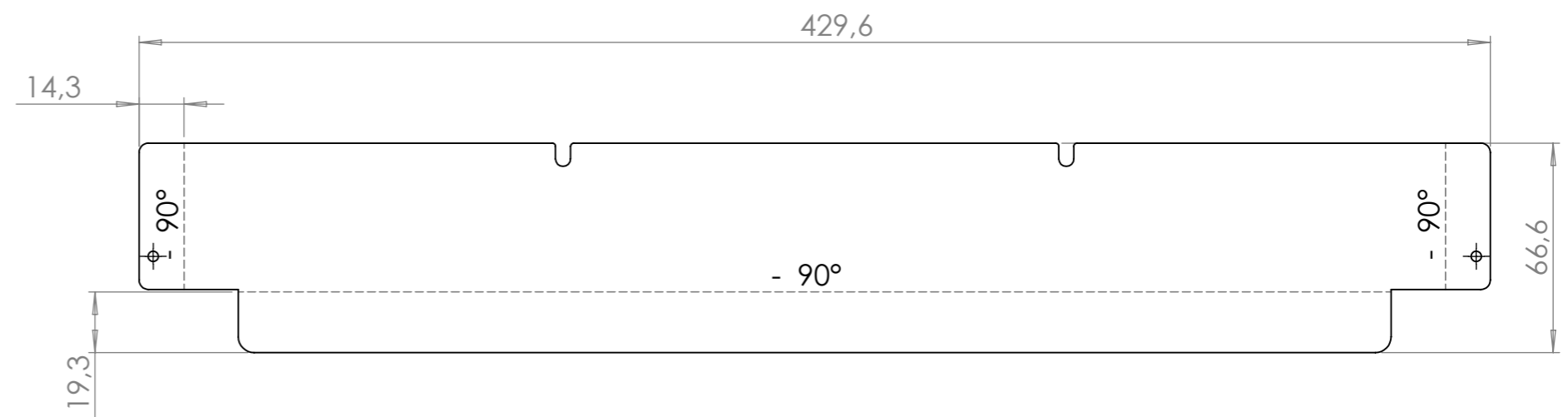

t=1mm Aluminium

| | | | | ENTGRATEN UND SCHARFE KANTEN BRECHEN | | ZEICHNUNG NICHT SKALIEREN | | Massstab: | | | | | | | | | | | | | | | | | | | | | | | | | |
|--|------|----------|------------|--------------------------------------|------|---------------------------|-------|------------|------|--|------------|---------|--|--|--|-----------|--|--|--|------------|--|--|--|----------|--|--|--|--------------------------------------|--|--|--|--|--|
| | | | | WERKSTOFF: 3.3535 (EN-AW 5754) | | GEWICHT: 0.07 | | | | | | | | | | | | | | | | | | | | | | | | | | | |
| <table border="1"> <thead> <tr> <th></th> <th>NAME</th> <th>SIGNATUR</th> <th>DATUM</th> </tr> </thead> <tbody> <tr> <td>GEZEICHNET</td> <td>West</td> <td></td> <td>28.01.2021</td> </tr> <tr> <td>GEPRÜFT</td> <td></td> <td></td> <td></td> </tr> <tr> <td>GENEHMIGT</td> <td></td> <td></td> <td></td> </tr> <tr> <td>PRODUKTION</td> <td></td> <td></td> <td></td> </tr> <tr> <td>QUALITÄT</td> <td></td> <td></td> <td></td> </tr> </tbody> </table> | | | | | NAME | SIGNATUR | DATUM | GEZEICHNET | West | | 28.01.2021 | GEPRÜFT | | | | GENEHMIGT | | | | PRODUKTION | | | | QUALITÄT | | | | BENENNUNG: Anschlag Filter | | | | | |
| | NAME | SIGNATUR | DATUM | | | | | | | | | | | | | | | | | | | | | | | | | | | | | | |
| GEZEICHNET | West | | 28.01.2021 | | | | | | | | | | | | | | | | | | | | | | | | | | | | | | |
| GEPRÜFT | | | | | | | | | | | | | | | | | | | | | | | | | | | | | | | | | |
| GENEHMIGT | | | | | | | | | | | | | | | | | | | | | | | | | | | | | | | | | |
| PRODUKTION | | | | | | | | | | | | | | | | | | | | | | | | | | | | | | | | | |
| QUALITÄT | | | | | | | | | | | | | | | | | | | | | | | | | | | | | | | | | |
| | | | | ZEICHNUNGSNR. CAS-01-08 | | A3 | | | | | | | | | | | | | | | | | | | | | | | | | | | |
| | | | | ÄNDERUNG | | BLATT 8 VON 11 | | | | | | | | | | | | | | | | | | | | | | | | | | | |

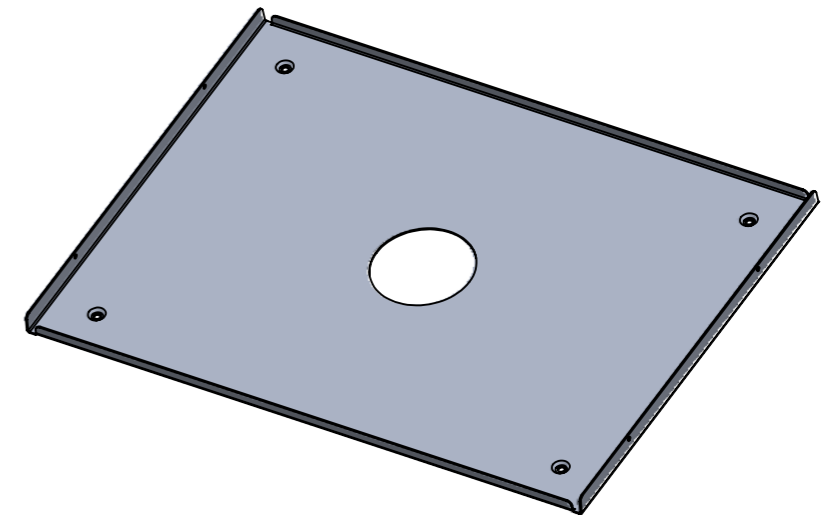
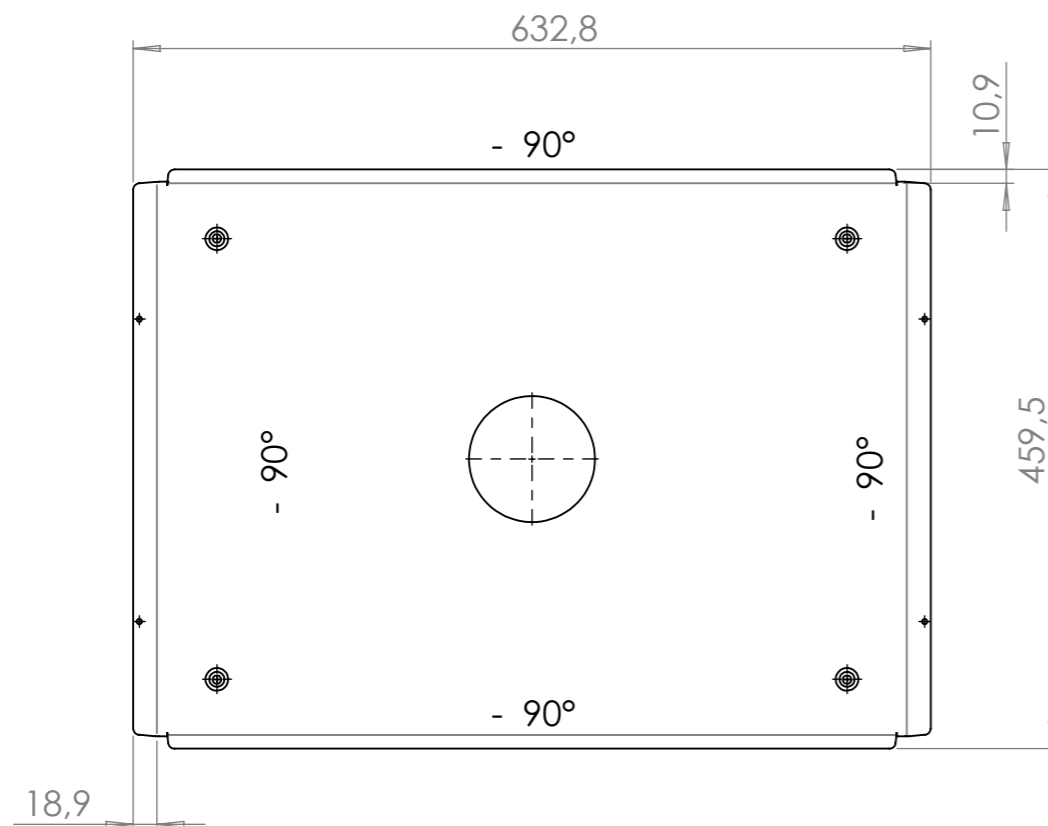
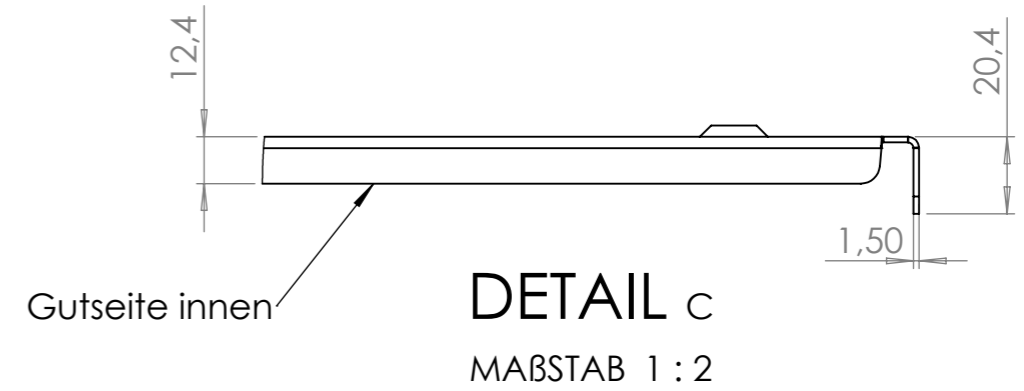
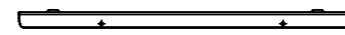
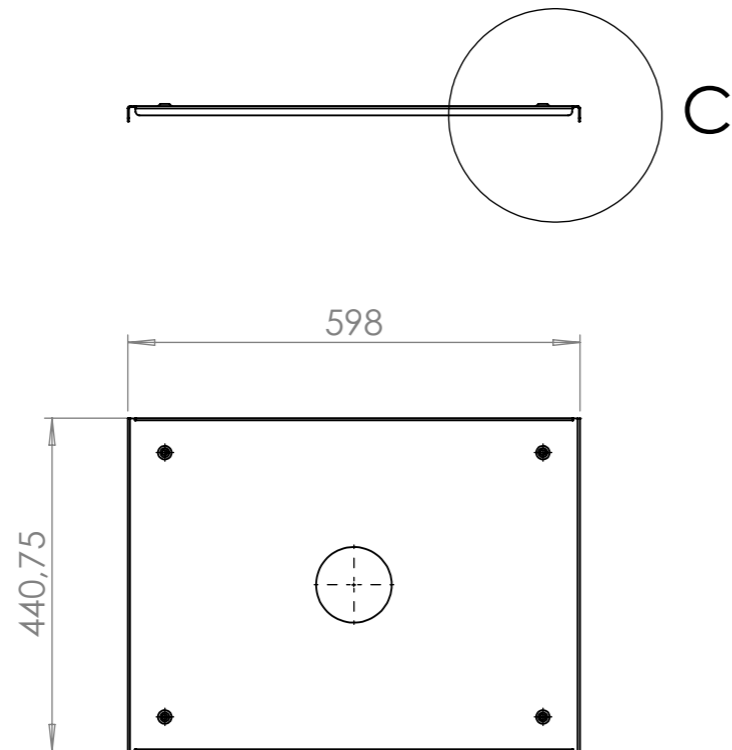

t=1,5mm Aluminium

| | | | | ENTGRATEN UND SCHARFE KANTEN BRECHEN | | ZEICHNUNG NICHT SKALIEREN | | Massstab: | | | | | | | | | | | | | | | | | | | | | | | | | | | | | | | | | | | | | | | |
|--|------|----------|------------|--------------------------------------|------|---------------------------|-------|-----------|--|------------|------|--|------------|--|--|---------|--|--|--|--|--|-----------|--|--|--|--|--|------------|--|--|--|--|--|----------|--|--|--|--|--|---|--|--|--|----------------------------|--|----|--|
| | | | | WERKSTOFF: 3.3535 (EN-AW 5754) | | GEWICHT: 1.13 | | | | | | | | | | | | | | | | | | | | | | | | | | | | | | | | | | | | | | | | | |
| <table border="1"> <thead> <tr> <th></th> <th>NAME</th> <th>SIGNATUR</th> <th>DATUM</th> <th></th> <th></th> </tr> </thead> <tbody> <tr> <td>GEZEICHNET</td> <td>West</td> <td></td> <td>28.01.2021</td> <td></td> <td></td> </tr> <tr> <td>GEPRÜFT</td> <td></td> <td></td> <td></td> <td></td> <td></td> </tr> <tr> <td>GENEHMIGT</td> <td></td> <td></td> <td></td> <td></td> <td></td> </tr> <tr> <td>PRODUKTION</td> <td></td> <td></td> <td></td> <td></td> <td></td> </tr> <tr> <td>QUALITÄT</td> <td></td> <td></td> <td></td> <td></td> <td></td> </tr> </tbody> </table> | | | | | NAME | SIGNATUR | DATUM | | | GEZEICHNET | West | | 28.01.2021 | | | GEPRÜFT | | | | | | GENEHMIGT | | | | | | PRODUKTION | | | | | | QUALITÄT | | | | | | BENENNUNG: Deckenmontageblech | | | | ZEICHNUNGSNR. CAS-01-09 | | A3 | |
| | NAME | SIGNATUR | DATUM | | | | | | | | | | | | | | | | | | | | | | | | | | | | | | | | | | | | | | | | | | | | |
| GEZEICHNET | West | | 28.01.2021 | | | | | | | | | | | | | | | | | | | | | | | | | | | | | | | | | | | | | | | | | | | | |
| GEPRÜFT | | | | | | | | | | | | | | | | | | | | | | | | | | | | | | | | | | | | | | | | | | | | | | | |
| GENEHMIGT | | | | | | | | | | | | | | | | | | | | | | | | | | | | | | | | | | | | | | | | | | | | | | | |
| PRODUKTION | | | | | | | | | | | | | | | | | | | | | | | | | | | | | | | | | | | | | | | | | | | | | | | |
| QUALITÄT | | | | | | | | | | | | | | | | | | | | | | | | | | | | | | | | | | | | | | | | | | | | | | | |
| | | | | ÄNDERUNG | | BLATT 9 VON 11 | | | | | | | | | | | | | | | | | | | | | | | | | | | | | | | | | | | | | | | | | |

2 STK

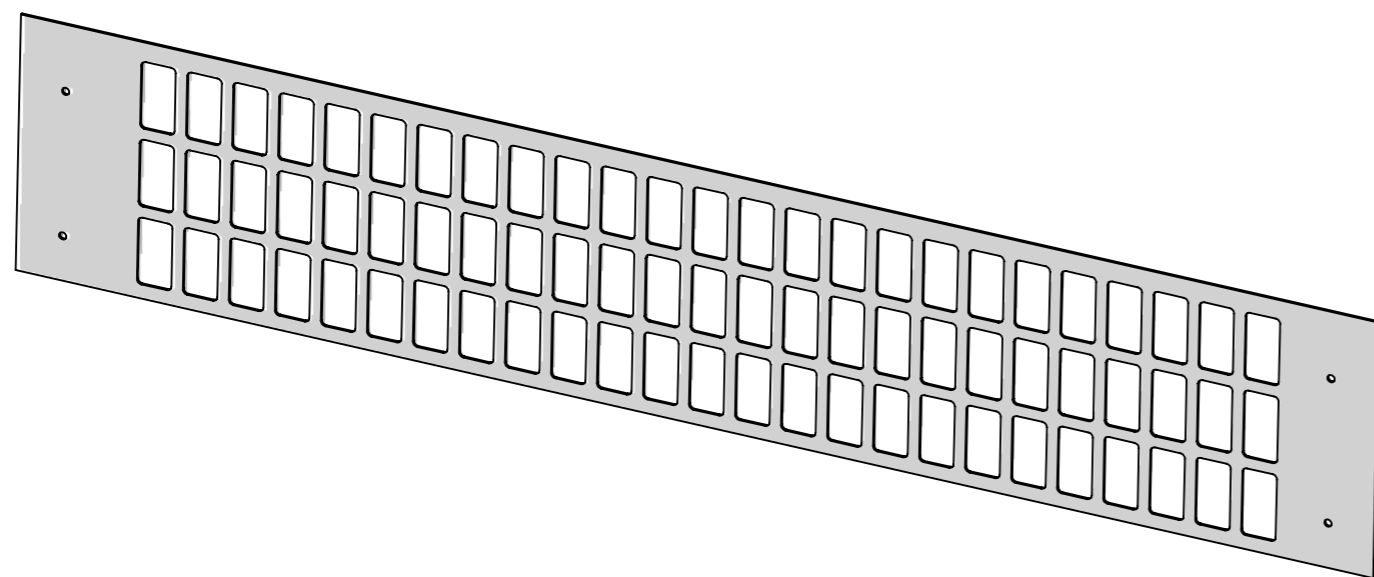
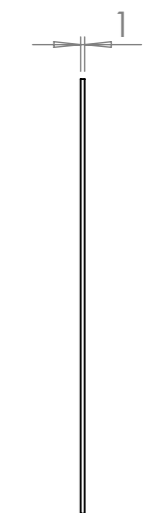
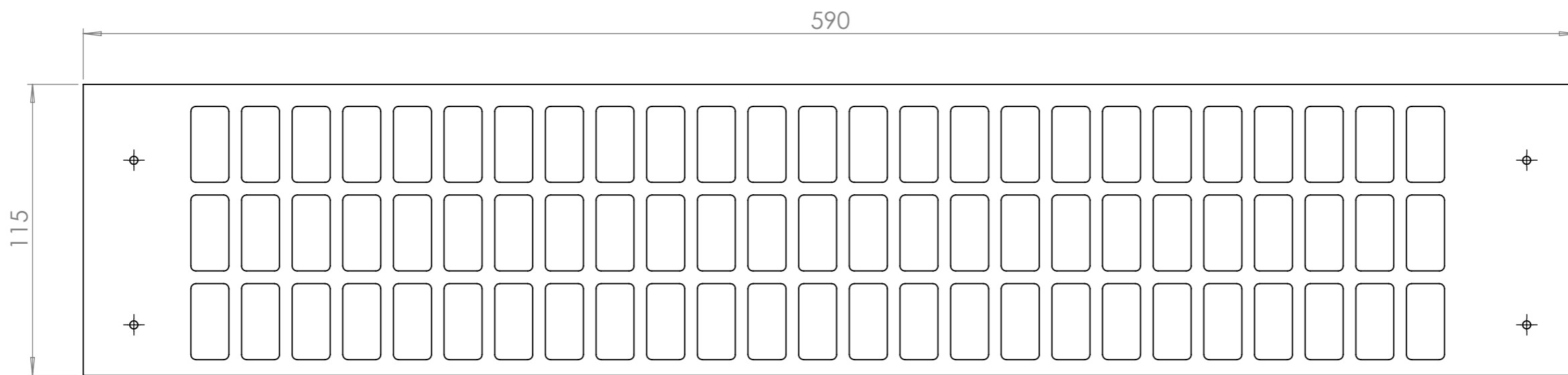

t=1mm Aluminium

| | | | | | | | | | | | |
|---|------|----------|------------|--------------------------------------|--|---------------------------|--|-----------------|----|--|--|
|  | | | | ENTGRATEN UND SCHARFE KANTEN BRECHEN | | ZEICHNUNG NICHT SKALIEREN | | Massstab: | | | |
| | | | | WERKSTOFF: 3.3535 (EN-AW 5754) | | GEWICHT: 0.09 | | | | | |
| | | | | BENENNUNG: Schutzgitter | | | | | | | |
| | | | | ZEICHNUNGSNR. CAS-01-10 | | | | | A3 | | |
| | | | | ÄNDERUNG | | | | BLATT 10 VON 11 | | | |
| GEZEICHNET | NAME | SIGNATUR | DATUM | | | | | | | | |
| GEPRÜFT | West | | 28.01.2021 | | | | | | | | |
| GENEHMIGT | | | | | | | | | | | |
| PRODUKTION | | | | | | | | | | | |
| QUALITÄT | | | | | | | | | | | |

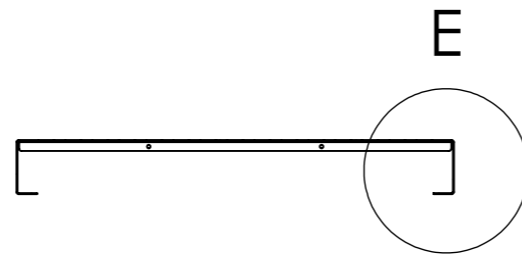
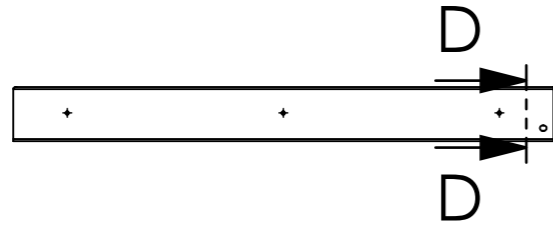

SCHNITT D-D
MABSTAB 1:7

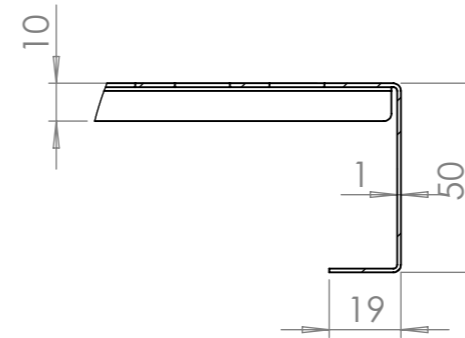
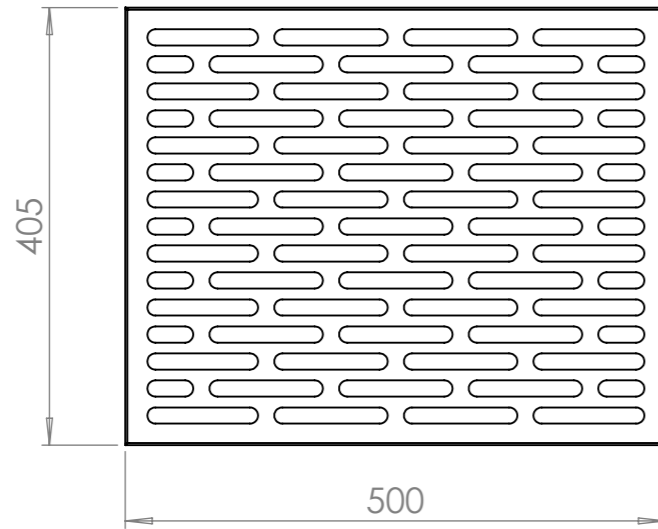

DETAIL E
MABSTAB 1:2

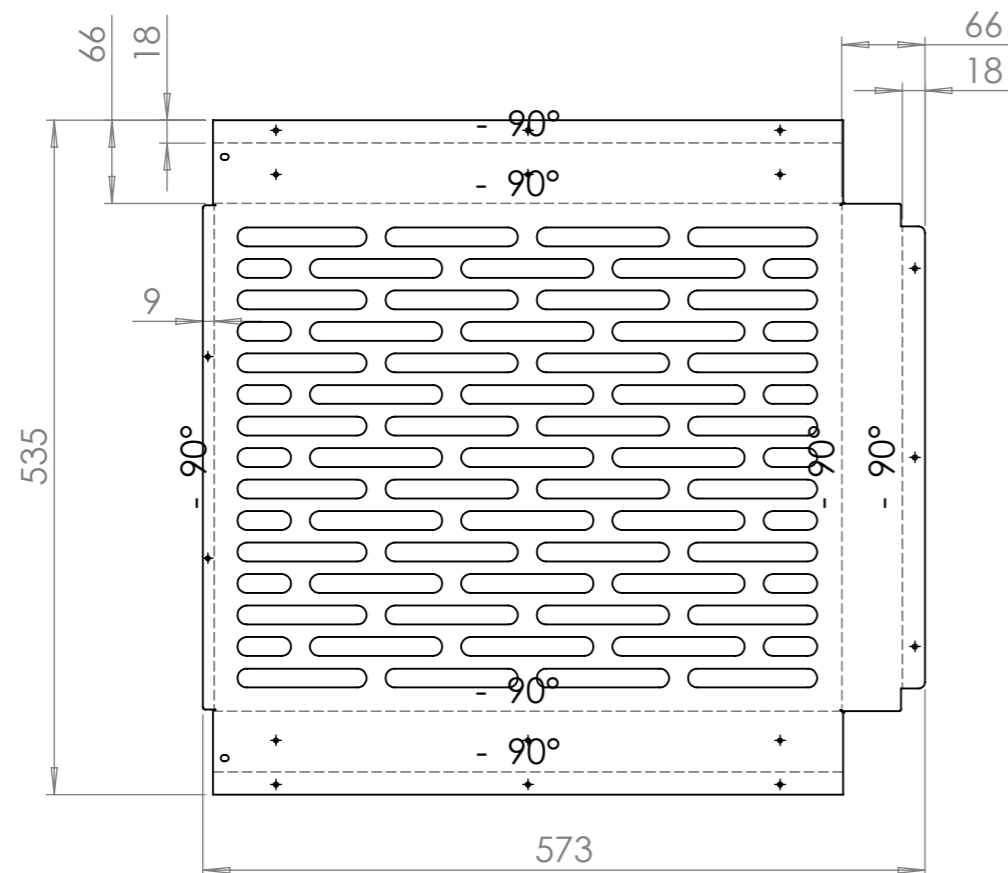
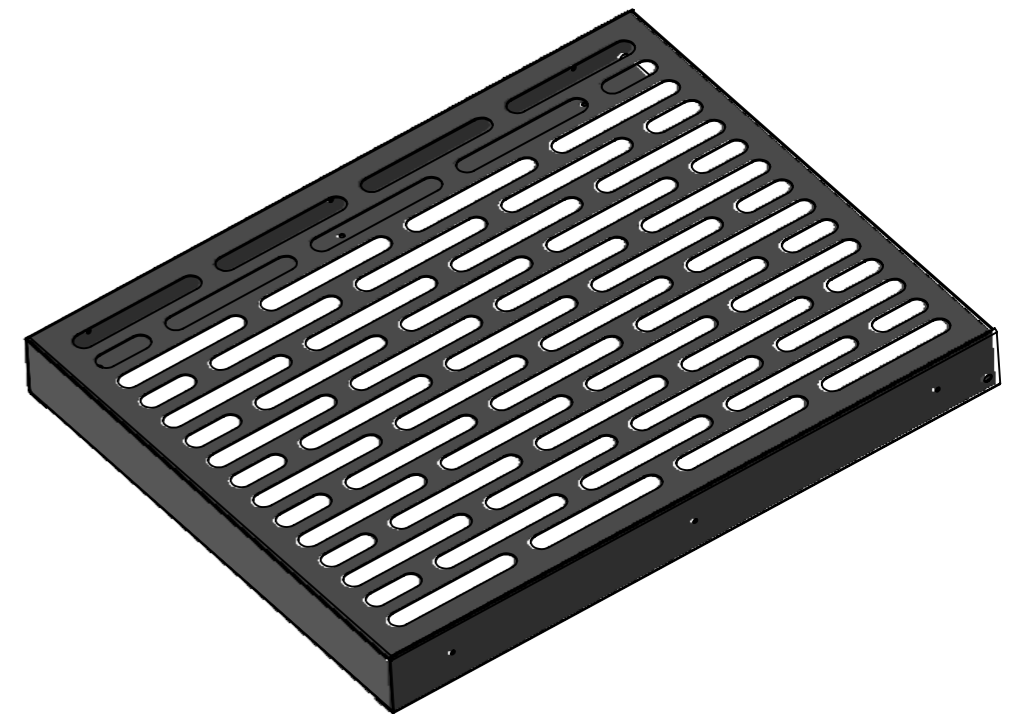

t=1mm Aluminium

|  | | | | ENTGRATEN UND SCHARFE KANTEN BRECHEN | | ZEICHNUNG NICHT SKALIEREN | | Massstab: | | | | | | | | | | | | | | | | | | | | | | | | | | | | | | | | | | | | | | | | | | | | | | | | | | | | | | | | | | | | | | | |
|--|------|----------|------------|--------------------------------------|------|---------------------------|-------|-----------------|--|--|--|--|--|------------|------|--|------------|--|--|--|--|--|--|---------|--|--|--|--|--|--|--|--|--|-----------|--|--|--|--|--|--|--|--|--|------------|--|--|--|--|--|--|--|--|--|----------|--|--|--|--|--|--|--|--|--|---|--|--|--|--|--|--|--|
| | | | | WERKSTOFF: 3.3535 (EN-AW 5754) | | GEWICHT: 0.55 | | | | | | | | | | | | | | | | | | | | | | | | | | | | | | | | | | | | | | | | | | | | | | | | | | | | | | | | | | | | | | | | | |
| <table border="1"> <thead> <tr> <th></th> <th>NAME</th> <th>SIGNATUR</th> <th>DATUM</th> <th></th> <th></th> <th></th> <th></th> <th></th> <th></th> </tr> </thead> <tbody> <tr> <td>GEZEICHNET</td> <td>West</td> <td></td> <td>28.01.2021</td> <td></td> <td></td> <td></td> <td></td> <td></td> <td></td> </tr> <tr> <td>GEPRÜFT</td> <td></td> <td></td> <td></td> <td></td> <td></td> <td></td> <td></td> <td></td> <td></td> </tr> <tr> <td>GENEHMIGT</td> <td></td> <td></td> <td></td> <td></td> <td></td> <td></td> <td></td> <td></td> <td></td> </tr> <tr> <td>PRODUKTION</td> <td></td> <td></td> <td></td> <td></td> <td></td> <td></td> <td></td> <td></td> <td></td> </tr> <tr> <td>QUALITÄT</td> <td></td> <td></td> <td></td> <td></td> <td></td> <td></td> <td></td> <td></td> <td></td> </tr> </tbody> </table> | | | | | NAME | SIGNATUR | DATUM | | | | | | | GEZEICHNET | West | | 28.01.2021 | | | | | | | GEPRÜFT | | | | | | | | | | GENEHMIGT | | | | | | | | | | PRODUKTION | | | | | | | | | | QUALITÄT | | | | | | | | | | BENENNUNG: Gitter Ansaugseite | | | | | | | |
| | NAME | SIGNATUR | DATUM | | | | | | | | | | | | | | | | | | | | | | | | | | | | | | | | | | | | | | | | | | | | | | | | | | | | | | | | | | | | | | | | | | | | |
| GEZEICHNET | West | | 28.01.2021 | | | | | | | | | | | | | | | | | | | | | | | | | | | | | | | | | | | | | | | | | | | | | | | | | | | | | | | | | | | | | | | | | | | | |
| GEPRÜFT | | | | | | | | | | | | | | | | | | | | | | | | | | | | | | | | | | | | | | | | | | | | | | | | | | | | | | | | | | | | | | | | | | | | | | | |
| GENEHMIGT | | | | | | | | | | | | | | | | | | | | | | | | | | | | | | | | | | | | | | | | | | | | | | | | | | | | | | | | | | | | | | | | | | | | | | | |
| PRODUKTION | | | | | | | | | | | | | | | | | | | | | | | | | | | | | | | | | | | | | | | | | | | | | | | | | | | | | | | | | | | | | | | | | | | | | | | |
| QUALITÄT | | | | | | | | | | | | | | | | | | | | | | | | | | | | | | | | | | | | | | | | | | | | | | | | | | | | | | | | | | | | | | | | | | | | | | | |
| | | | | ZEICHNUNGSNR. CAS-01-06 | | | | A3 | | | | | | | | | | | | | | | | | | | | | | | | | | | | | | | | | | | | | | | | | | | | | | | | | | | | | | | | | | | | | | | |
| | | | | ÄNDERUNG | | | | BLATT 11 VON 11 | | | | | | | | | | | | | | | | | | | | | | | | | | | | | | | | | | | | | | | | | | | | | | | | | | | | | | | | | | | | | | | |